

D11T/ D11T CD

Track-Type Tractor



Engine

| | | |
|----------------|-----------------|--------|
| Engine Model | Cat® C32 ACERT™ | |
| Flywheel Power | 634 kW | 850 hp |

Weights

| | | |
|------------------|------------|------------|
| Operating Weight | 104 590 kg | 230,100 lb |
| Shipping Weight | 74 418 kg | 163,200 lb |

- **Operating Weight:** Includes lubricant, coolant, full fuel tank, hydraulic controls and fluids, 810 mm (32 in) extreme service shoes, 11U ABR bulldozer, single-shank ripper with pin puller and fast fuel, engine doors (optional equipment) and operator.
- **Shipping Weight:** Includes lubricants, coolant, 20% fuel, and ROPS with FOPS cab.

| | | |
|-----------------------|------------|------------|
| Operating Weight – CD | 113 000 kg | 248,600 lb |
|-----------------------|------------|------------|

| | | |
|----------------------|-----------|------------|
| Shipping Weight – CD | 75 455 kg | 166,000 lb |
|----------------------|-----------|------------|

- **Operating Weight:** Includes lubricant, coolant, full fuel tank, hydraulic controls and fluids, 910 mm (36 in) extreme service shoes, 11 carrydozer, single-shank ripper (optional equipment) and operator.
- **Shipping Weight:** Includes lubricants, coolant, 20% fuel, and ROPS with FOPS cab.

D11T/D11T CD Track-Type Tractor

Strength from the past. Power for the future.™ The D11T/CD combines power and efficiency with advanced technology for outstanding production at a lower cost-per-yard.

C32 with ACERT™ Technology

ACERT™ Technology works at the point of combustion to optimize engine performance and to provide low exhaust emissions. Matched with the torque divider and power shift transmission, it provides years of dependable and efficient service. **pg. 4**

Cooling System

The Advanced Modular Cooling System (AMOCS) combines higher cooling capacity with easier servicing. AMOCS allows the machine to be operated in the most demanding environments with less downtime. **pg. 6**

Implement and Steering Controls

Electro-hydraulic implement controls allow low operator effort for dozing and ripping. Steering and gear selection in a one-hand control system enhances operator comfort. **pg. 7**

Undercarriage

The proven elevated sprocket undercarriage isolates the drive train components from ground-induced impacts. The suspended undercarriage puts more track on the ground for higher traction and less track slip. It absorbs shocks for a smoother ride and longer machine life. **pg. 12**

Work Tools

Various bulldozer blades, rippers, winches, and other options allow you to adapt the D11T to match your specific application, making you more productive. The CarryDozer blade can handle larger loads to maximize productivity. **pg. 13**

Engineered for demanding work.

The durable construction of the D11T is well suited for tough working conditions. Combined with the Cat® C32 ACERT™ engine for superior performance, fuel economy and meeting emission targets, it keeps material moving with the reliability and low operating costs you expect from Cat® tractors.



Operator Station

- ✓ Designed for operator comfort, convenience, and productivity. Machine control and vital information is provided at the operator's fingertips. A full day of work is no problem in this efficient work place. **pg. 8**

Drive Train

The electronically controlled power shift transmission, efficient clutch/brake steering and durable planetary final drives deliver outstanding power transfer and long life to ensure maximum productivity. **pg. 10**

Structure

Mainframe is heavy, strong and durable. Full box sections, steel castings and continuous rolled rails provide durable support to the suspended undercarriage, elevated final drives and other integral frame components. **pg. 11**

Safety

Caterpillar® has been and continues to be proactive in developing machines that meet or exceed safety standards. Safety is an integral part of all machine and systems designs. **pg. 14**

Serviceability and Customer Support

Combining easy-to-access, modular components with your Caterpillar Dealer's advanced rebuild and repair capabilities ensure rapid component replacement and minimum downtime. **pg. 15**



✓ *New Feature*

C32 with ACERT™ Technology

A combination of innovations working at the point of combustion, ACERT™ Technology optimizes engine performance while meeting EPA Tier 2 and EU Stage II engine exhaust emission regulations for off road applications.



C32 Engine. Performing at full rated net power of 634 kW (850 hp) at 1,800 rpm with a high torque rise of 21 percent, the large displacement and high torque allow the D11T to doze through tough material. Matched to the high efficiency torque divider and electronically controlled power shift transmission, it will provide years of dependable service.

C32 Block. The block features a design that adds structural strength through compaction and thicker walls. This design supports the engine's higher compression ratios.

Overhead Cams. Two, single (one per head) overhead cams are driven by gears on the flywheel end of the engine. Placing the cam gears at the flywheel end significantly reduces noise and vibration. To reduce wear, two pendulum absorbers are mounted at the front of the camshafts. Together, these two features contribute to the long-life and durability of this engine.

ADEM™ A4 Engine Controller.

The ADEM A4 electronic control module manages fuel delivery and air flow to get the best performance per gallon (liter) of fuel used. It provides flexible fuel mapping, allowing the engine to respond quickly to varying application needs. It keeps track of engine and machine conditions while keeping the engine operating at peak efficiency.

Fuel Delivery. Multiple injection fuel delivery involves a high degree of precision. Precisely shaping the combustion cycle lowers combustion chamber temperatures, generating fewer emissions and optimizing fuel combustion; translating into more work output for your fuel used.

MEUI Fuel System. A highly evolved fuel system with a proven record of reliability in the field. MEUI combines the technical advancement of an electronic control system with the simplicity of direct mechanically controlled unit fuel injection. The MEUI system excels in its ability to control injection pressure over the entire engine operating speed range. These features allow the C32 to have complete control over injection timing, duration, and pressure.

ATAAC and Airflow. Air-to-air aftercooling keeps air intake temperatures down and, in concert with the tight tolerance combustion chamber components, maximizes fuel efficiency and minimizes emissions. Significant improvements in air flow are generated by water-cooled turbochargers, unique cross-flow head, single rear-driven overhead cams, and a more efficient intake manifold.

Engine maintenance and repair. Is easier through monitoring key functions and logging critical indicators. Electronic diagnostic access is possible with the Electronic Technician (Cat ET).

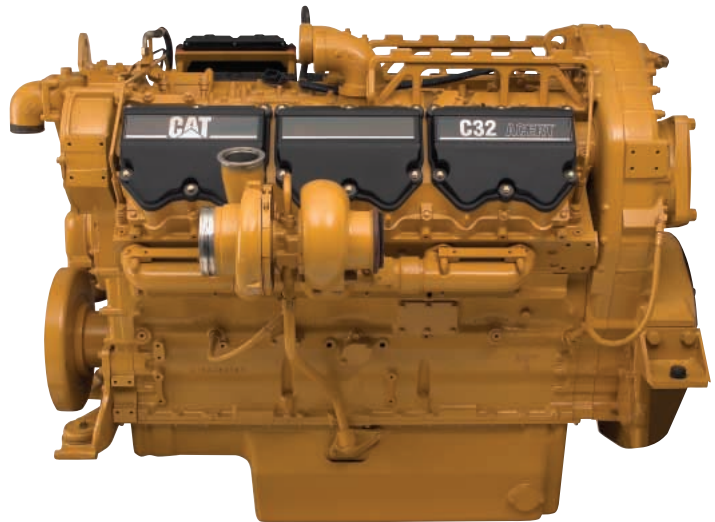

Aluminum Spacer. Located between the block and head to eliminate the need for block counterbores, and extend block life.

Hardened-faced valves. Through-hardened crankshaft journals and steel-backed, copper-bonded aluminum bearings, help assure reliable performance in the toughest duty.

Components have longer life. Because oil-cooled pistons and full-length, water-cooled cylinder liners provide maximum heat transfer. The cylinder heads also utilize additional coolant passages to provide maximum cooling to the engine.

Cooling System

Superior cooling in the most demanding work conditions.

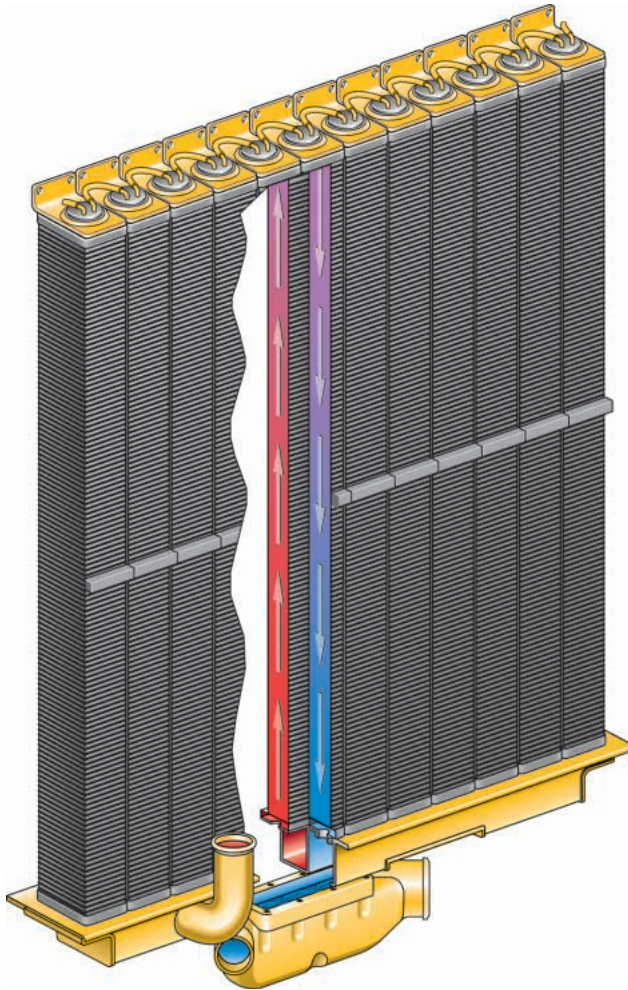

Two-pass cooling system. Using a two-pass system, the AMOCS radiator provides a more efficient heat exchange. The coolant is routed from a sectioned bottom tank up the front side, over the top of the core, and down the engine side of the core to the bottom tank. This flow pattern allows the coolant to pass through the radiator twice for better cooling.

Modular Design. The cooling elements are individual core modules connected to a sectioned bottom tank. There is no top tank to remove.

- Standard 9.4 steel fins per 2.54 cm (1 in), or an optional 6 steel fins per 2.54 cm (1 in)
- Brass tube construction within each core for improved reliability

Hydraulically Variable, Demand Fan.

The hydraulically driven demand fan provides engine cooling capability that is matched to the ambient conditions. In cooler conditions, the fan turns at a slower speed, reducing power demands. This frees up more power in high load factor operations or reduces fuel consumption in lower load factor operations. Low speed fan operation also reduces both operator and spectator sound levels. The ADEM A4 engine controller regulates the fan speed through a variable displacement pump. An attachment low speed option is available for cold weather operations to avoid over cooling the engine.

Easy Serviceability.

- Servicing of the AMOCS can be performed without tilting the radiator guard
- No need to remove or replace a major component as on single-core radiators
- Each core module can be replaced individually (without removing the entire radiator), saving considerable cost and repair time

Implement and Steering Controls

Low effort control functions significantly reduce operator fatigue for increased performance.



Dozer Control Lever. A low-effort electronic dozer control handle gives the operator control of all dozer functions with one hand. Fore/aft movement of the lever lowers and raises the blade. Left/right movement directionally tilts the blade.

The thumb lever at the top of the handle, controls blade pitch fore and aft. The trigger switch pitches the blade forward to dump the load.

The two thumb buttons to the left of the implement control provide control over the semi-automated blade pitch functions that Dual Tilt provides. Blade pitch for load, carry and spread segments can be preset on Advisor and controlled by the buttons. The left side button cycles between the pitch settings for each segment of the push cycle. The right side button cancels out of the pitch functions without losing the preset pitch angles. This Auto Blade Assist (ABA) feature is turned on and off using a switch on the right side console.

Computer Aided Earthmoving System (CAES) (optional).

Computer Aided Earthmoving Systems (CAES) replace conventional surveying with advanced GPS and radio communications equipment, improving operator's accuracy and efficiency. CAES can communicate back and forth with the office and access site design plans. Office software can generate designs on the fly and provide customized production and design reports. CAES gives operators continuous, interactive access to machine and operating information right in the cab – so they have the tools they need to operate with more precision and predictability. An in-cab display gives operators easy-to-understand color diagrams of where to cut and fill. With CAES, the effort of reading maps or looking for grade stakes is virtually eliminated. And because it gives immediate, accurate feedback, operators can doze quickly, accurately and confidently. CAES helps identify ways to reduce errors and constantly improve the production process – ultimately helping reduce cost.

AutoCarry (optional). AutoCarry provides automatic blade control (raise and lower only) during the carry segment of the dozing cycle. Drawbar pull, ground speed, track slip, and machine attitude are integrated to control track slip and maintain optimal blade loads. AutoCarry is intended to enhance the operator's productivity in high production earthmoving with carry distances over 30.5 m (100 ft). By monitoring ground speed with the belly-mounted radar gun, the auto carry system controls blade load to maintain approximately 2.4 km/h (1.5 mph) true ground speed. Track slip is monitored and limited to under 16%. Readouts of the true ground speed and track slip are available in the AutoCarry menu on Advisor. Through the system's Dynamic Inclination Sensor (DIS), readouts of the tractor pitch angle and side-to-side scope are also available on Advisor.



Ripper Control Lever. A rigidly mounted handgrip provides firm support for the operator even when ripping in the roughest terrain. The low effort thumb lever controls raising and lowering. The finger lever controls shank-in and shank-out positioning. The thumb button automatically raises the ripper.



Finger Tip Controls (FTC). Clustered for easy, one-hand operation to the operator's left. They control steering, machine direction and gear selection.

Electronic Clutch and Brake (ECB) steering System – consists of two small levers that send signals that control the steering valve. Levers require less than three pounds of pull to actuate. Steering is accomplished in much the same way as traditional clutch and brake arrangements, but with less time and effort.

Operator Station

Designed for operator comfort, convenience, and productivity, the state-of-the-art cab sets a new standard.



1) Steering Control. Finger Tip Control (FTC) combines steering, machine direction and gear selection into a single control system, operated with one hand for enhanced operator comfort.

2) Cat Comfort Series Seat.

Fully adjustable and designed for comfort and support. Thick seat and back cushions provide support for the lower back and thighs, while allowing unrestricted arm and leg movement. Wide retractable seat belt provides positive, comfortable restraint.

3) Adjustable Armrests. Standard adjustable armrests provide additional comfort for the operator.



4) Electronic Ripper Control. A rigidly mounted handgrip, with low effort thumb and finger controls, provides firm support and positive control of the ripper when operating in tough conditions. Programmable features, such as Auto Lift, Shank-Out and Auto Stow, increase operator efficiency.

5) Electronic, Programmable Dozer Control. Features such as blade response, blade float, auto blade pitch, and spread rate can be set and adjusted using the Advisor panel. Auto Blade Assist (standard) and AutoCarry (optional) make the tractor even more efficient in specific applications.

6) Cat Monitoring Display System.

The combination dash mounted instrument cluster and the Advisor Monitoring System provide key machine operating data and give the operator and service technician insight into the machine's operation and maintenance needs.

In-Dash Instrument Cluster.

The instrument panel, with easy-to-read gauges and warning lamps, keeps the operator aware of any potential problems. All gauges and readouts are easily visible in direct sunlight.

Advisor Monitoring System (AMS).

On-board diagnostic abilities minimize downtime and maximize machine performance.

7) Wide Panoramic View. The operator station offers an exceptional viewing area. A large view hole in the single-shank ripper frame provides a view of the ripper tip. The tapered hood, notched fuel tank, and narrow single-shank ripper carriage gives the operator a clear line of sight to the front and rear work areas. The large single-pane door windows provide an excellent view to the sides and blade.

8) Heating and Air Conditioning.

Conveniently located air circulation vents evenly distribute airflow within the cab. Controls are easily accessible from the operator seat.

High Intensity Discharge Lights (HID).

High Intensity Discharge lighting packages are standard to enhance visibility when 24 hours operations are required. The HID lights are bluish in color and offer less glare while significantly extending the sightlines around the tractor.



Fuse Panel and Diagnostic Access.

The new compartment features a single location fuse panel that includes a diagnostic port for the Cat ET to connect for rapid machine diagnostics.

Comfortable Operation. Standard isolation-mounted cab reduces noise and vibration. The cab is pre-wired for a 12-volt or 24-volt radio, equipped with two speakers, an antenna and a radio mount recessed in the headliner.

Footpads. Two footpads, mounted on the floor and wide, sweeping stabilizer pads keep the operator comfortable and in control while working on slopes.

Other Features. Built-in storage space with tie downs for lunch box or other personal items.

- Ashtray and cup holder.
- Inside door releases.
- Power point plug-in on the right hand console (12-volt laptop and wireless phone compatible).

Drive Train

The D11T/CD provides maximum efficiency in combination with the Cat C32 engine.

Torque Divider. A single-stage torque converter with output torque divider sends 75 percent of engine torque through the converter and 25 percent through a direct drive shaft for greater driveline efficiency and higher torque multiplication. The torque converter shields the driveline from sudden torque shocks and vibration.

High Torque Multiplication. The more efficient and better matched torque converter provides high drawbar pull reserves at converter stall. High torque multiplication gets heavy loads moving.

Elevated Final Drives. Isolated from ground and equipment induced impact loads for extended power train life.

- Double-reduction, planetary final drive gears provide smooth, quiet, low-maintenance operation.
- Splash lubrication and Duo-Cone® Seals extend service life.
- Gears and planet carriers are sized for higher loads and increased durability.
- Axle and spline have been enlarged for higher torque.

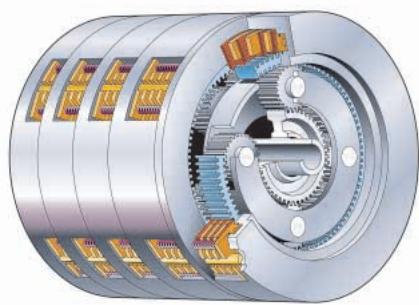

Planetary Power Shift Transmission.

Three speeds forward and three speeds reverse, utilizing large diameter, high-capacity, oil-cooled clutches.

- Modulation system permits fast speed and direction changes.
- Modular transmission and bevel gear slide into rear case for servicing ease, even with ripper installed.
- Oil-to-water cooler for maximum cooling capacity.
- Forced oil flow lubricates and cools clutch packs to provide maximum clutch life.
- Controlled throttle shifting regulates engine speed during directional shifts for smoother operation and longer component life.
- Size of bevel group unit increased for higher torque.

Electronic Clutch Pressure Control.

The Finger Tip Control (FTC) system has an additional drive train feature for added performance, Electronic Clutch Pressure Control (ECPC). This feature provides smoother shifting by modulating individual clutches. ECPC also provides the auto-shift and auto-kickdown feature.

Auto-Shift/Auto-Kickdown. Auto-shift allows the operator, by just making a directional change, to go from first forward to second reverse.

Auto-kickdown automatically downshifts the transmission when significant load increases are detected. These features are especially useful in backfilling or rough grading applications or with a less skilled operator. Depending on application, operators can select auto-shift mode only, auto-shift and auto-kickdown mode only, or manual mode. The operator may override these automatic shift features at any time.

D11T Brakes. The brakes are applied by springs and hydraulically released for safe and reliable braking performance.

- Thick, large diameter plates and disks provide high torque capacity and service life.
- Brake housing has cast-in-ribs for more durability and a new valve design.
- Cooling oil valve controls 284 L (75 gal) of oil per minute.
- Clutch disks allow greater torque capacity on the clutch.
- Tapered roller bearing design provides excellent service life.

D11T/D11T CD Drawbar Pull

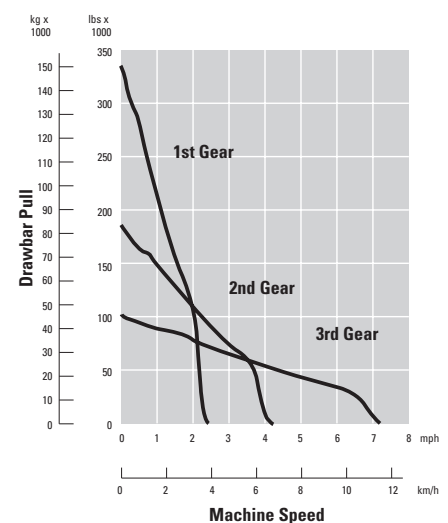

Drawbar Pull vs Ground Speed.

As loads on the tractor increase, the D11T offers unmatched lugging capability and smooth shifting as the need occurs to change gears under varying loads. The 3-speed forward, 3-speed reverse transmission offers excellent runout speeds.

Modular Power Train. The modular power train design permits quick removal and installation of major components such as the engine, transmission and final drives.

Structure

Engineered to provide durability and the solid support necessary for maximum production and service life in the most demanding work.

Mainframe Strength. The D11T and D11T CD mainframes are built to absorb high impact shock loads and twisting forces of severe dozing and ripping. The two frames share the following features:

Frame Rails. Full box section design keeps components rigidly aligned.

Heavy Steel Castings. Strengthen the main case, equalizer bar saddle, front cross member and tag-link trunnion.

Top and Bottom Rails. Made from continuous rolled sections to eliminate welds and machining, which provide superior mainframe durability.

Main Case. Elevates the final drives well above the ground level work area to protect them from impact loads, abrasion and contaminants. Also provides support for the ROPS and ripper mounting.

Pivot Shaft. The pivot shaft and pinned equalizer bar maintain track roller frame alignment.

Case and frame design. Features one-piece cast case with ripper and ROPS mounting. Oil reservoir included in one-piece cast casting.

Heavy cast saddle. Ribbed design increases frame life.

Engine and Radiator Guard Mount.

The new fabricated common front engine and rear radiator mount feature heavy castings.

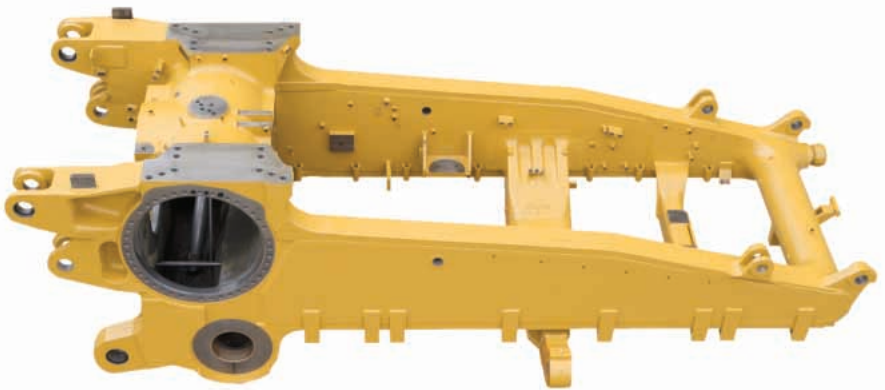

CarryDozer Frame. The CarryDozer frame is specifically designed for the carrying material long distances. The taller front end accepts additional frame loads generated by the unique CarryDozer blade design.



Tag-Link. Reduces wear and brings the blade closer to the machine for more precise dozing and load control.

- The Tag-Link design provides solid lateral stability and better cylinder positions for constant break out force, independent of blade height.

Undercarriage

The Caterpillar elevated sprockets are designed for better machine balance and longer component life.



Suspended Undercarriage Design.

Absorbs impact loads to reduce the shock loads transferred to the undercarriage by up to 50 percent in uneven terrain.

Bogie suspension conforms closely to the ground. Providing up to 15 percent more ground contact, especially in hard, uneven terrain. Higher traction means less slippage, better balance, and a smoother ride.

Sprockets. Have five bolt-on replaceable rim segments of abrasion resistant tough steel for long wear life.

Equalizer Bar. End pin bearings are oil lubricated from a remote reservoir for easy maintenance and longer life.

Rollers and Idlers. Feature symmetric Duo-Cone seals for long sealing life to prevent oil loss and dirt entry. Toric rings maintain performance over a wide range of temperatures. Rollers and idlers are serviceable and rebuildable to provide value. Abutment-style caps securely attach rollers and idlers to the bogies.



Integrated Carrier Roller Mount.

The carrier roller mount is cast into the track roller frame making it easier to add the optional carrier roller in the field, if conditions require it.

Reinforced Roller Frames. Tubular design resists bending and twisting, with added reinforcement where operating loads are highest.

- Roller frames attach to tractor by a pivot shaft and pinned equalizer bar.
- Large pivot shaft bushings operate in an oil reservoir.
- A low friction, no maintenance bushing is used in the saddle connection.
- Resilient pads restrain equalizer bar oscillation.
- The recoil system is sealed and lubricated.
- Patented alignment design increases undercarriage wear life.
- Idler guards (optional) increase undercarriage life in abrasive applications.
- Track adjustment provided to 120 percent undercarriage wear limit.

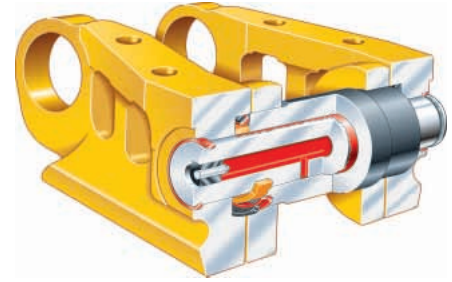

Positive Pin Retention (PPR) Sealed and Lubricated Track. Permanently coats the track pin with a sealed-in lubricant, minimizing metal-to-metal contact.

- Virtually eliminates internal pin and bushing wear.
- Lubricant is held in a reservoir in the track pin.
- Coated track bushing maximizes sealability.
- Stronger track link resists high impact loads.
- Positive pin retention mechanically locks the link to the pin, resisting end play and increasing joint stability.

Sprocket Segments. Made exclusively of Caterpillar Tough Steel™ for longer wear life and precision machined after heat treat for proper fit. Segments can be removed or replaced without breaking the track.

Track Shoes. Track shoes are available in a variety of sizes and styles to match the working conditions.

Work Tools

Work Tools and Ground Engaging Tools (G.E.T.) provide the flexibility to match the machine to the job, maximizing performance.



Bulldozers. All blades feature a strong box-section design that resists twisting and cracking. Blades are made of Cat DH-2™ steel that has high tensile strength and stands up to the most severe applications. Heavy moldboard construction and hardened bolt-on cutting edges and end bits add strength and durability.

• **Semi-Universal Blade.** Built for tough applications where penetration is more important than capacity. The “SU” blade is more aggressive in penetrating and loading material than the “U” blade. The blade wings are designed for superior load retention and penetration in tightly packed materials and for finishing applications. Can also be configured with a push plate for push loading scrapers.

• **High-Capacity Universal Blade.**

Offers maximum capacity and is perfect for moving big loads over long distances. The “U” blade has large blade wings and is ideal for stockpile work, reclamation, charging hoppers or trapping for loaders.

CarryDozer Blade. The CarryDozer carries material inside the blade curvature, rather than pushing it. This carried material increases the effective weight of the tractor, enabling larger loads in front of the blade and enhancing operation on steeper uphill slopes. These two effects combine to maximize productivity.

• **Abrasion Versions.** The abrasion versions of the “SU” blade and “U” blade extend blade life in more severe applications. Abrasion blades are equipped with rock guards, wear plates and extended wear life cutting edges and end bits.

Dual Tilt. Improves load control and allows the operator to optimize the blade pitch angle for each portion of the dozing cycle.

Single Lever. Controls all blade movements, including the optional dual tilt.

Cutting Edges and End Bits. Cutting edges are made of DH-2 steel. End bits are made of DH-3™ steel to provide maximum service life in tough materials.

Rippers. Single and multi-shank rippers are made to penetrate tough material fast and rip thoroughly for use in a variety of materials.

Single-Shank Ripper. Operator can adjust the shank depth from the seat using an optional single-shank pin puller. Large upper frame view hole improves ripper tip visibility. Heat treated spacer bars in ripper carriage extend pocket life and reduce shank notching. Large one-piece shank is available in deep ripping configuration.



Multi-Shank Ripper. Tailors the tractor to the material by using one, two or three shanks.

Hydraulic Pitch Adjustment Cylinders. Hydraulic pitch adjustment cylinders vary the shank angle to get the best penetration so the material is lifted and shattered.

Rear Counterweights. Provide proper tractor balance to maximize dozing production. Recommended if not equipped with any other rear attachment.

Safety

Caterpillar mining machines and systems are designed with safety as the first priority.

Product Safety. Caterpillar has been and continues to be proactive in developing mining machines that meet or exceed safety standards. Safety is an integral part of all machine and systems designs.

ASE and ISO Standards. The D11T/ CarryDozer is designed to many national and international standards.

ROPS and FOPS. The external ROPS/ FOPS structure is designed to carry loads directly into the tractor main frame and protect the operator.



Access/Egress. Wide opening cab doors provide both primary and secondary access/egress from the cab. Primary and secondary access are via the platform outside the cab doors and the track, using strategically placed grab irons and steps. An attachment rear walkway [with 1987 L (505 gal) fuel tank] is available to provide a means of cleaning the rear and side windows and provides maintenance access to the rear lights. An attachment, hydraulically actuated, access ladder is available, separately, for applications where wet or freezing material would make access/egress via the tracks more challenging.

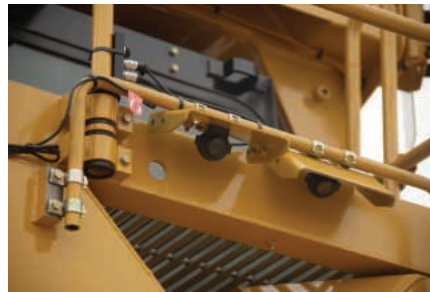

Visibility. An attachment WAVS rear vision camera is available to provide additional visibility to the standard mirrors.

Electrical System Lockout/Tagout.

A disconnect switch is available to shut off all machine electrical power. Another disconnect switch shuts off power to the starter, while keeping main power available for diagnostics and troubleshooting.

Lighting. Standard HID lighting provides superior illumination around the machine for night operations. The 35 watt HID lamps provide lighting equivalent to 4 Halogen lamps, without producing significant glare. Multiple switches in the cab allow segregation of specific lamps in the event that the tractor is working near other machines. Two under-hood service lamps illuminate the engine compartment for easy night service. The fender light switch can be left in the on position when the ignition key is turned off. The fender lights will stay on for a pre-timed period to allow the operator to egress the machine at night. The fender lights will automatically turn off after 10 minutes.

SAFETY.CAT.COM™.

Serviceability and Customer Support

The most serviceable machines from the most committed dealers. World-class product support. The Cat Dealer network trained experts keep your fleet up and running, maximizing your equipment investments. Caterpillar. The difference counts.™

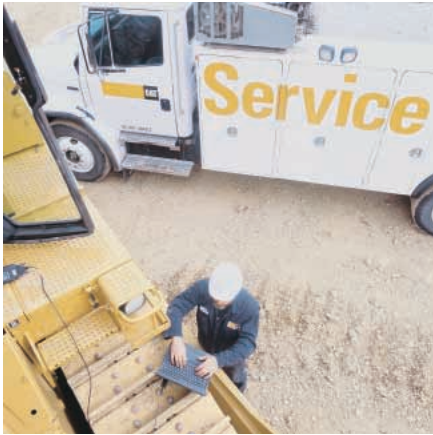

Serviceability. Minimizes maintenance and repair downtime. New sight gauges, filter locations, improved access to oil and coolant sampling ports, and an engine compartment mounted work lamp, make daily and periodic service faster and easier. Equipped with a dozer and ripper, there are only 18 lube points.

Built-in Servicing Ease. Less service time means more working time. Major components are made as modules and most can be removed without disturbing or removing others.

Heater and Air Conditioner Cores. Accessible without disconnecting heater and air conditioner cores are accessible without disconnecting lines. A diagnostic connector allows the Cat Dealer's electronic test instrument to quickly troubleshoot the electrical portions of these systems.

Ecology Drains. An environmental method to drain fluids. They are included on the radiator, hydraulic tank, fuel tank, torque divider and transmission.

Engine Oil Filters. Engine oil filters are located on the engine for easy servicing access and minimal downtime. Further time is saved with fast fuel and quick oil change attachments.

Quick Disconnect Fittings. Allow for fast diagnosis of the power train, hydraulics and attachment oil systems.

S-O-SSM Analysis. Scheduled Oil Sampling made easier through live sampling ports for the engine oil, hydraulics and coolant.

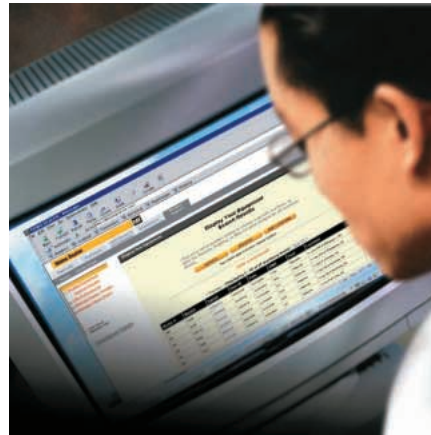

Caterpillar Product Link PL300 (optional).

This option allows the customer or dealer to obtain machine diagnostics and location information from their offices. Product Link PL300 provides updates on service meter hours, machine condition and machine location, as well as integrated mapping/route planning. Built-in flexibility allows for future technology development.

Machine Selection. Make detailed comparisons of the machines you are considering before you buy. How long do components last? What is the cost of preventive maintenance? What is the true cost of lost production? Your Cat Dealer can give you answers to these very important questions.

Purchase. Consider the financing options available as well as day-to-day operating costs. This is also the time to look at dealer services that can be included in the cost of the machine to yield lower equipment owning and operating costs over the long run.

Product Support. Plan for effective maintenance before buying equipment. Choose from your dealer's wide range of maintenance services at the time you purchase your machine. Programs such as Custom Track Service (CTS), S-O-S analysis, Technical Analysis and guaranteed maintenance contracts give peak life and performance to your machine.



Parts Program. You will find nearly all parts at your dealer parts counter. Cat Dealers use a world-wide computer network to find in-stock parts to minimize machine downtime.

Ask about your Cat Dealer's exchange program for major components. This can shorten repair time and lower costs.

Remanufactured Components. Genuine Cat Remanufactured parts save you money. You receive the same warranty and reliability as new products at cost savings of 40 to 70 percent. Components are available for the drive train, engine, and hydraulics.

Operation. Improving operating techniques can boost your profits. Your Cat Dealer has training videotapes, literature, and other ideas to help you increase productivity.

Replacement. Repair, rebuild or replace? Your Cat Dealer can help you evaluate the costs involved so you can make the right choice.

Engine

| | | |
|-------------------------|---|-----------------------|
| Engine Model | Four-stroke cycle, V12, Cat C32 Diesel Engine | |
| Gross Power | 698 kW | 935 hp |
| Flywheel Power | 634 kW | 850 hp |
| Net Power – Caterpillar | 634 kW | 850 hp |
| Net Power – ISO 9249 | 634 kW | 850 hp |
| Net Power – ISO 3046-2 | 634 kW | 850 hp |
| Net Power – EEC 80/1269 | 634 kW | 850 hp |
| Bore | 145 mm | 5.71 in |
| Stroke | 162 mm | 6.38 in |
| Displacement | 32.1 L | 1,959 in ³ |

- Engine ratings apply at 1,800 rpm.
- Based on standard conditions of 25° C (77° F) and 99 kPa (29.32 in. Hg) dry barometer.
- Used 35° API gravity fuel having an LHV of 42 780 kJ/kg (18,390 Btu/lb) when used at 30° C (86° F) [ref. a fuel density of 838.9 g/L (7.001 lb/U.S. gal)].
- Net power advertised is the power available at the flywheel when the engine is equipped with fan, air cleaner, muffler, and alternator.
- No derating required up to 2286 m (7,500 ft) altitude, beyond 2286 m (7,500 ft) automatic derating occurs.

D11T/D11T CD Drawbar Pull

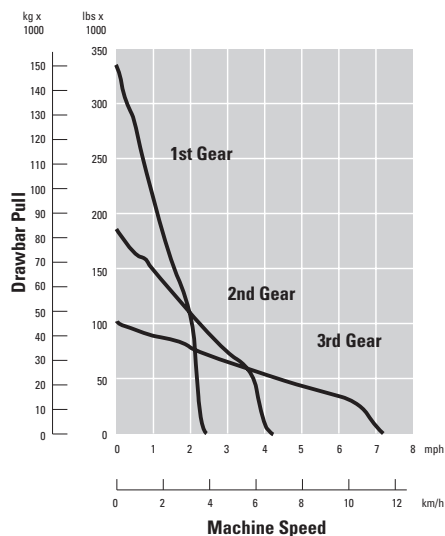

Features

- Meets EPA and CARB emissions requirements for 2006
- Single piece design for outstanding structural rigidity
- Mechanical Electronic Unit Injection (MEUI) and ADEM A4 allows variable injection timing and controls the quantity of fuel
- Twin wastegate turbochargers provide higher boost over a wider range that will improve engine response, outstanding low end performance and improved peak torque
- Forged steel design piston provides higher strength, lighter weight, better oil control, and less liner wear
- Cylinder liners are hardened plateau honed to reduce wear, reduce blow-by and improve oil control and consumption
- Leak free design by improving joints throughout the engine and all fluid connections using the standard thread 'O' ring design

Final Drives

Double-reduction planetary final drive gears with tapered roller bearings.

Features

- Splash lubricated and sealed with Duo-Cone® floating ring seals
- Sprockets have five bolt-on, replaceable rim segments with more bolts to resist high impact loads
- Eliminate ground and implement induced impact loads for extended power train life
- Abrasion-resistant steel increases sprocket segment wear life

Transmission

| | | |
|-----------|-----------|---------|
| 1 Forward | 3.9 km/h | 2.4 mph |
| 2 Forward | 6.8 km/h | 4.2 mph |
| 3 Forward | 11.8 km/h | 7.3 mph |
| 1 Reverse | 4.7 km/h | 5.9 mph |
| 2 Reverse | 8.2 km/h | 5.1 mph |
| 3 Reverse | 14.0 km/h | 8.7 mph |

Features

- Special modulation system permits fast speed and direction changes
- 533 mm (21 in) diameter, high torque capacity oil-cooled clutches
- Exclusive F 37 friction material for excellent life
- Modular transmission, bevel gear, and differential plug into rear of main drive case
- Two oil-to-water coolers mounted under radiator
- Single-stage torque converter with output torque divider
- Double universal joint eases service

Service Refill Capacities

| | | |
|--------------------------------------|---------|----------|
| Fuel Tank | 1609 L | 425 gal |
| Optional Fuel Tank | 1987 L | 505 gal |
| Cooling System | 238.8 L | 63 gal |
| Engine Crankcase | 106 L | 28 gal |
| Power Train | 344 L | 91 gal |
| Final Drives (each) | 30 L | 8 gal |
| Roller Frames (each) | 95 L | 25.1 gal |
| Pivot Shaft Compartment | 51 L | 13.5 gal |
| Implement Hydraulic System Tank Only | 243 L | 64 gal |

D11T Weights (approximate)

| | | |
|------------------|------------|------------|
| Operating Weight | 104 590 kg | 230,100 lb |
| Shipping Weight | 74 4182 kg | 163,200 lb |

- Operating Weight: Includes lubricant, coolant, full fuel tank, hydraulic controls and fluids, 810 mm (32 in) extreme service shoes, 11U ABR bulldozer, single-shank ripper with pin puller and fast fuel, engine doors (optional equipment) and operator.
- Shipping Weight: Includes lubricants, coolant, 20% fuel, and ROPS with FOPS cab.

D11T CD Weights (approximate)

| | | |
|------------------|------------|------------|
| Operating Weight | 113 000 kg | 248,600 lb |
| Shipping Weight | 75 455 kg | 166,000 lb |

- Operating Weight: Includes lubricant, coolant, full fuel tank, hydraulic controls and fluids, 910 mm (36 in) extreme service shoes, 11 carrydozer, single-shank ripper (optional equipment) and operator.
- Shipping Weight: Includes lubricants, coolant, 20% fuel, and ROPS with FOPS cab.

Cab

| | |
|------------|--------------------|
| ISO 3471-1 | 1986 ROPS |
| ISO 3471-1 | 1994 ROPS |
| ISO 3449 | 1992 LEVEL II FOPS |

- Caterpillar cab and Rollover Protective Structure (ROPS) are standard in North America, Europe, and Japan.

Sealed and Lubricated Track

Positive Pin Retention (PPR) for extra protection of track seal in high impact conditions.

| | | |
|---|--------------------|------------------------|
| Pitch | 318 mm | 12.5 in |
| Number Shoes/Side | 41 | |
| Shoe Type | Extreme service | |
| Width of Shoe | | |
| D11T | 710 mm | 28.0 in |
| D11T CD | 910 mm | 36.0 in |
| Length of Track on Ground | 4444 mm | 14 ft 7 in |
| Ground Contact Area | | |
| D11T | 6.3 m ² | 9,781 in ² |
| D11T CD | 8.1 m ² | 12,581 in ² |
| Grouser Height (from ground face of shoe) | 102 mm | 4.0 in |
| Ground Clearance | 623 mm | 24.5 in |
| Gauge | 2896 mm | 9 ft 6 in |

Features

- Sleeve bearing track
- Lubricant reduces internal bushing wear
- Hydraulic track adjusters; track guiding guards; and large, positive clamping, two-piece master link are standard
- Improved track joint sealability
- Stronger track link to resist high impact loads

Track Roller Frame

| | | |
|-------------|--------|---------|
| Oscillation | 362 mm | 14.3 in |
|-------------|--------|---------|

Features

- Lifetime lubricated rollers and idlers resiliently mounted to roller frame by a series of bogies
- Tubular design resists torsional loads
- Bogies oscillate on sealed and lubricated cartridge pin connections, travel controlled by resilient pads
- Roller frame attaches by a pivot shaft and fully pinned equalizer bar
- Eight rollers per side
- Large pivot bushing operate in an oil reservoir
- Equalizer bar-roller frame ball joint pins and high capacity bearings have improved seal and operate in oil reservoir
- Improved center bearing in equalizer bar for improved life. Improved pin corrosion resistance, provides ease of serviceability
- Recoil system is fully sealed and lubricated
- Large idler caps with three-bolt mounting

Steering and Brakes

Electronic Finger Tip Controls (FTC) combine steering clutch disengagement and braking for each track. Pull back slightly to disengage steering clutches, fully back to brake track.

- Low-effort Finger Tip Controls for steering
- Hydraulically applied multiple-disk clutches
- High capacity brakes are hydraulically released, spring applied, and have computerized electronic brake control for excellent brake modulation
- Single pedal simultaneously applies brakes to tracks for fast stops
- Parking brake applied electronically, which engages parking brake and locks the Finger Tip Controls
- High capacity (high power dissipation)
- Large diameter disks 610 mm (24 in)

Hydraulic Controls

Complete system consists of pump, tank with filter, oil cooler, valves, lines, linkage and control levers.

Attachments – Gear-type pump (D11T)

| | | |
|--|------------|-----------|
| Output at 1,890 rpm and 6895 kPa (1,000 psi) | 620 L/min | 164 gpm |
| Tilt Cylinder Flow | 155 L/min | 41 gpm |
| Bulldozer Relief Valve Settings | 22 750 kPa | 3,300 psi |
| Tilt Cylinder Relief Valve Settings | 24 300 kPa | 3,525 psi |
| Ripper (Lift) Relief Valve Settings | 22 750 kPa | 3,300 psi |
| Ripper (Pitch) Relief Valve Settings | 22 750 kPa | 3,300 psi |

Attachments – Gear-type pump (D11T CD)

| | | |
|--|------------|-----------|
| Output at 1,890 rpm and 6895 kPa (1,000 psi) | 670 L/min | 177 gpm |
| Tilt Cylinder Flow | 250 L/min | 66 gpm |
| CarryDozer Relief Valve Settings | 24 135 kPa | 3,500 psi |
| Dump Cylinder Relief Valve Settings | 24 825 kPa | 3,600 psi |
| Ripper (Lift) Relief Valve Settings | 24 135 kPa | 3,500 psi |
| Ripper (Pitch) Relief Valve Settings | 24 135 kPa | 3,500 psi |

Electro-hydraulic pilot valves assist operations of ripper and dozer tilt controls. Standard hydraulic systems include two valves for carrydozer and dump, and a regeneration valve for quick dump.

Standard Ripper Control

Two additional valves for ripper function

- Hydraulic shank pitch adjustment
- Optional pin pull on hydraulics

Dimensions – D11T

All dimensions are approximate.

With attachments add to overall machine length:

| | | |
|--|---------|---------|
| Single-shank ripper | 1850 mm | 6' 1" |
| Single-shank ripper with push block | 2190 mm | 7' 2.2" |
| Multi-shank ripper | 1915 mm | 6' 3.4" |
| 11SU Dozer | 2220 mm | 7' 3.4" |
| 11U Dozer | 2668 mm | 8' 9" |

| | | |
|---|---------|--------|
| Width over trunnions | 4365 mm | 14' 4" |
| Drawbar height (centerline of clevis) from ground face of shoe | 777 mm | 30.6" |

Note: model shown equipped with 710 mm (28") shoes.

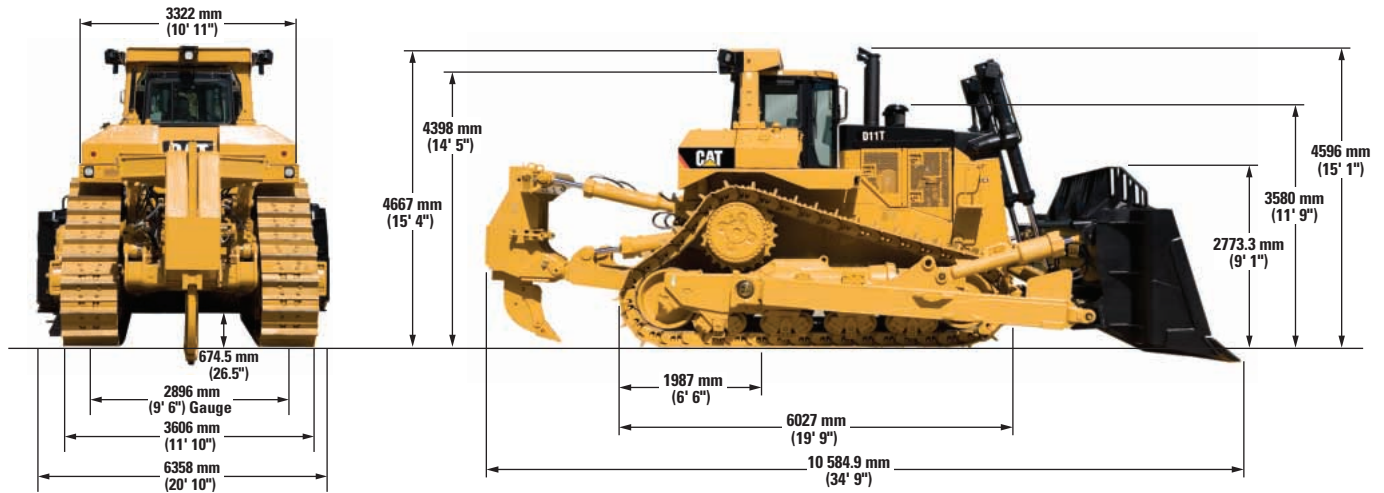

Dimensions – D11T CD

All dimensions are approximate.

With attachments add to overall machine length:

| | | |
|----------------------|---------|---------|
| Single-shank ripper | 2156 mm | 7' 0.7" |
| Multi-shank ripper | 1935 mm | 6' 4" |
| 11 Carrydozer | 2178 mm | 7' 1.5" |
| Width over trunnions | 4365 mm | 14' 4" |

Note: model shown equipped with 910 mm (36") shoes.

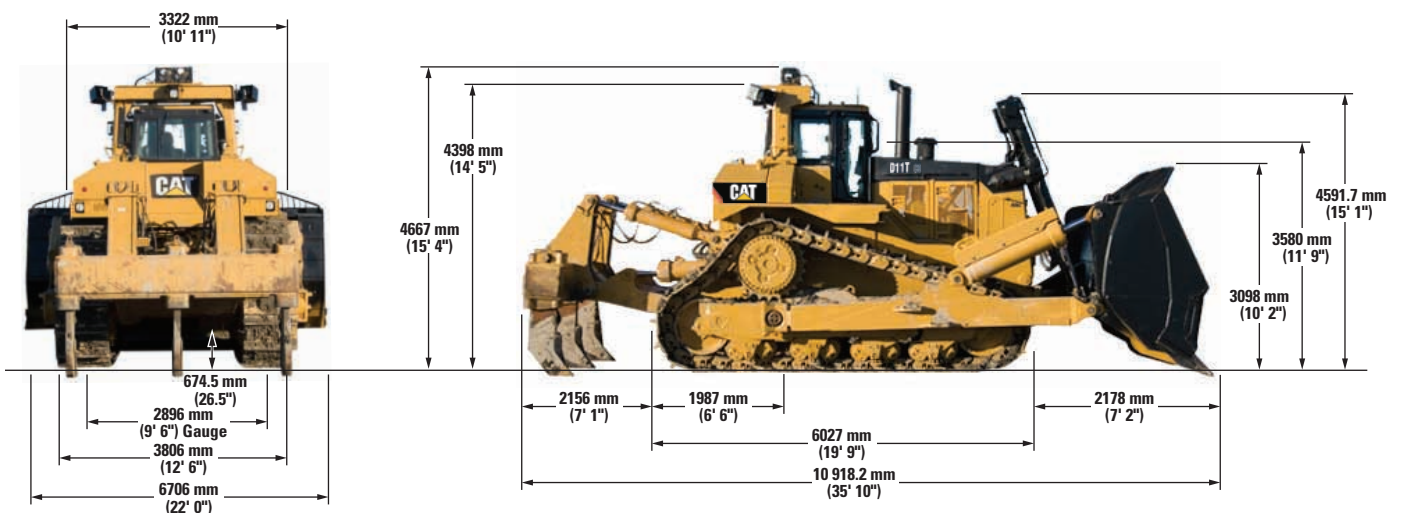

D11T Bulldozer

Tag link dozer coupling brings blade closer for better balance and control.

| Blade | | 11SU ABR | 11U ABR | 11SU | 11U | |
|---|-----------------|----------|---------|---------|---------|---------|
| Blade capacity (SAE J1265) | m ³ | 27.2 | 34.4 | 27.2 | 34.4 | |
| | yd ³ | 35.5 | 45.0 | 35.5 | 45.0 | |
| Width with blade (over end bits) | mm | 5600 | 6358 | 5600 | 6358 | |
| | ft/in | 18'4" | 20'10" | 18'4" | 20'10" | |
| Blade height | mm | 2773 | 2773 | 2773 | 2773 | |
| | ft/in | 9'1" | 9'1" | 9'1" | 9'1" | |
| Digging depth | mm | 766 | 766 | 766 | 766 | |
| | in | 30.2 | 30.2 | 30.2 | 30.2 | |
| Ground clearance | mm | 1533 | 1533 | 1533 | 1533 | |
| | ft/in | 5'0" | 5'0" | 5'0" | 5'0" | |
| Maximum tilt | mm | 1184 | 1344 | 1184 | 1344 | |
| | ft/in | 3'11" | 4'5" | 3'11" | 4'5" | |
| Weight* | kg | 16 192 | 18 823 | 14 813 | 17 296 | |
| | lb | 35,698 | 41,498 | 32,658 | 38,131 | |
| Total operating weight** (with blade and single-shank ripper) | | kg | 101 955 | 104 590 | 100 573 | 103 060 |
| | | lb | 224,300 | 230,100 | 221,260 | 226,733 |

*Does not include hydraulic controls but includes blade cylinders.

**Includes blade and single-shank ripper, hydraulic controls, blade cylinders, coolant, lubricants, full fuel tank, 810 mm (32 in) shoes, ROPS, FOPS cab, and operator.

Features

- Dual-tilt is standard for improved blade loading, carrying, and dumping
- Cutting edges are DH-2 steel and end bits are DH-3 steel for maximum durability
- Dozer lift cylinders mount to top corners of radiator guard to improve mechanical advantage
- Single lever controls all blade functions
- Aggressive heel clearance for improved blade penetration

D11T CD Bulldozer

Tag link dozer coupling brings blade closer for better balance and control.

CarryDozer Blade

| | | | |
|---|-----------------|---------|-------|
| Blade capacity | m ³ | 43.6 | |
| | yd ³ | 57.0 | |
| Width with blade (over end bits) | mm | 6706 | |
| | ft/in | 22'0" | |
| Blade height w/cutting edge at 53° | mm | 2740 | |
| | ft/in | 9'0" | |
| Blade height w/cutting edge at 53° and rock guard | mm | 3255 | |
| | ft/in | 10'8" | |
| Digging depth | | | |
| | Rack back | mm | 688 |
| | | in | 27.1" |
| Full dump | mm | 1708 | |
| | in | 67.2" | |
| Ground clearance | | | |
| | Rack back | mm | 1846 |
| | | ft/in | 6'1" |
| Full dump | mm | 307 | |
| | ft/in | 12.1" | |
| Maximum tilt | mm | 1800 | |
| | ft/in | 5'11" | |
| Weight* | kg | 23 600 | |
| | lb | 51,920 | |
| Total operating weight** | kg | 113 000 | |
| | lb | 248,600 | |

* Does not include hydraulic controls but includes blade cylinders.

** Includes blade and single-shank ripper, hydraulic controls, blade cylinders, coolant, lubricants, full fuel tank, 910 mm (36 in) shoes, ROPS, FOPS cab, and operator.

Features

- Dual-tilt/dump cylinders are standard for improved blade loading, carrying, and dumping
- Cutting edges and end bits are DH-2 steel for maximum durability
- Dozer lift cylinders mount to top corners of radiator guard to improve mechanical advantage
- Single lever controls all blade functions
- Aggressive heel clearance for improved blade penetration
- Rock guard
- Wear plates
- Router protectors

Ripper

Redesigned ripper frame for improved visibility to ripper tip. Hydraulic tip adjustment cylinders vary shank angle to aid penetration and help lift and shatter rock.

| | | D11T | | | D11T/D11T CD | D11T CD |
|---|-------|-------------------------------|---------------------------------------|---------------------------|----------------------------|---------------------------|
| | | Single-shank | Single-shank Deep Ripping Arrangement | + Multi-shank Arrangement | Single-shank | + Multi-shank Arrangement |
| Overall beam width | mm | — | — | 3330 | — | 3330 |
| | ft/in | — | — | 10'11" | — | 10'11" |
| Maximum penetration force* (shank vertical) | kN | 288 | 292 | 277 | 326 | 306 |
| | lb | 64,800 | 65,644 | 62,325 | 73,350 | 68,850 |
| Maximum penetration (standard tip) | mm | 1612 | 2172 | 1070 | 1612 | 1070 |
| | ft/in | 5'3" | 7'2" | 3'6" | 5'3" | 3'6" |
| Pryout force (multi-shank ripper with one tooth) | kN | 660 | 657 | 646 | 642 | 650 |
| | lb | 148,500 | 147,772 | 145,350 | 144,450 | 146,250 |
| Maximum clearance raised (under tip, pinned in bottom hole) | mm | 1115 | 878 | 1137 | 1115 | 1137 |
| | in | 43.9" | 34.6" | 44.8" | 43.9" | 44.8" |
| Number of shank holes | | 4 | 3 | 2 | 4 | 2 |
| Weight (without hydraulic controls) | kg | 9643 | 10 022 | 9698 | 12 733 | 12 025 |
| | lb | 21,215 | 22,050 | 21,335 | 28,076 | 26,515 |
| Total operating weight** | | with 11U ABR blade and ripper | | | with 11CD blade and ripper | |
| | kg | 104 590 | 104 970 | 104 485 | 113 000 | 112 521 |
| | lb | 230,100 | 230,935 | 229,867 | 248,600 | 247,039 |

* Specifications are converted from British to metric measure and rounded.

** Operating weight includes lubricant, coolant, full fuel tank, hydraulic controls, 810 mm (32 in) extreme service shoe, ROPS, FOPS cab, and operator.

+ Includes one shank. Add 671 kg (1,489 lb) for each additional shank.

Note: Single-shank, deep ripping arrangement weight includes required pin puller.

Features

- Optional single-shank pin puller lets operator adjust shank depth from seat
- Large one-piece shank
- Multi-shank ripper allows variable use of one, two, or three shanks to match job conditions

Standard Equipment

Standard equipment may vary. Consult your Caterpillar dealer for details.

ELECTRICAL

- Alarm, back-up
- Alternator, 100-amp
- Batteries, 12-volt (4), 190 amp-hour
- Converter, 12-volt, 10-amp
- Converter, 12-volt, 15 amp
- Deutsch electrical connectors
- Diagnostic connector
- Horn, forward warning
- Lighting system, 5 HID/4 Halogen
(2 forward, 2 rear)
- Receptacle, starting

OPERATOR ENVIRONMENT

- Advisor – electronic monitoring system
- Air conditioning
- Armrest, adjustable
- Deactivation switch, hydraulic controls
- Decelerator, governor switch
- Finger Tip Control (FTC) steering
- Heater
- Hydraulic system – electronically controlled for bulldozer control (lift, tilt, dump)
- Product Link ready cab
- Radio-ready cab
- Rearview mirror
- ROPS rollbar and FOPS sound suppressed cab
- Seat, air suspension
- Seatbelt, retractable 76 mm (3 in)
- Wipers, intermittent

POWER TRAIN

- Cat® C32 ACERT
 - 24-volt electric start
 - Air cleaner with precleaner (2)
- MEUI
 - Ether starting aid, automatic
 - Fuel priming pump, electric
 - Muffler with rain cap (2)
 - Turbocharged/aftercooled
- Advanced Modular Cooling System (AMOCS)
- Clutch and brake system, electronic
- Drains, ecology fluid
- Fan, suction with hydraulic demand drive
- Oil change system (for fast engine and drive train oil change)
- Parking brake, electronic
- Planetary final drives, 4-planet, double-reduction
- Powershift transmission (3 speed)
- Precleaner with dust ejector
- Torque divider
- Heater, engine coolant (120 volt)

UNDERCARRIAGE

- Grousers
 - D11T: 710 mm (28 in), D11T CD: 910 mm (36 in)
 - Extreme service
 - Sealed/lubricated PPR sleeve bearing track
 - Three bolt idler and roller caps
 - 41 section
- Hydraulic track adjusters
- Suspension-type undercarriage,
 - 8-roller tubular track roller frame
- Track guides

OTHER STANDARD EQUIPMENT

- CD ROM parts book
- Dual-tilt blade control
- Engine enclosures
- Fluid sampling ports
- Guards:
 - Bottom, extreme service, hinged, with front towing device
 - Hinged radiator
 - Hinged power train
- Vandalism, protection (8 caplocks)
- Ripper

Optional Equipment

Optional equipment may vary. Consult your Caterpillar dealer for details.

Air conditioner, ROPS mounted (R134A)

AutoCarry Blade Control System

Access Ladder

Bulldozer – D11T:

11SU Abrasion

(Semi-universal blade includes tilt cylinders, wear plates, rock guard, and extended wear life cutting edges and end bits.)

11U Abrasion

(Universal blade includes tilt cylinders, wear plates, rock guard, and extended wear life cutting edges and end bits.)

11SU

(Semi-universal blade includes push plate and general duty cutting edges and end bits. Does not include rock guard or wear plate.)

11U

(Universal blade includes push plate and general duty cutting edges and end bits. Does not include rock guard or wear plate.)

Bulldozer – D11T CarryDozer:

11 CarryDozer (Includes blade dump cylinders, wear plates, rock guard, pin-on edge protectors, and general duty cutting edges and end bits)

Cab, enhanced clean

Camera, WAVS, single rear

Camera, WAVS, dual rear

CAES ready option

Counterweight:

Rear (4990 kg/11,000 lb)

Rear (additional 2268 kg/5,000 lb)

Rear (extended 13 608 kg/30,000 lb)

Cylinder, single tilt

Fan, reduced minimum speed, arctic

Fast fill fuel system

Glass, ultra strength [276 kPa (40 psi)]

Grease point, ripper lines

Guards:

Final drive clamshell

Partial bottom

Transmission

Undercarriage

Heater, engine coolant (240 volt)

Heater, fuel

High altitude arrangement

Hydraulics:

Pin puller

Oil renewal system

Operators arrangement

(improves visibility and comfort for smaller operators)

Paint, black hood and cylinders

Pin puller

Prelube, engine automatic

Rippers – D11T:

Single shank

Single shank with extra counterweight (3175 kg/7,000 lb)

Multi-shank

Multi-shank, deep

Rippers – D11T CarryDozer:

Single shank, extra counterweight (3175 kg/7,000 lb)

Multi-shank, extra counterweight (12 700 kg/28,000 lb)

Roller, carrier

Roller frame, aligned straight

Rollers, single flange

Seat, vinyl

Tank, fuel, additional capacity (1987 L/505 gallons)

Tracks, pair 711 mm (28 in) ES (D11T only):

ARM grousers

Trapezoidal holes

Tracks, pair, 813 mm (32 in) ES (various options)

Stainless end treated bushings

ARM grousers

Trapezoidal holes

Tall, tough steel links (D11T only)

Tall, tough steel links and trapezoidal holes

Tracks, pair, 914 mm (36 in) ES (various options)

ARM grousers

Trapezoidal holes (D11T only)

Tall, tough steel links

Walkway, rear

Notes

D11T/D11T CD Track-Type Tractor

For more complete information on Cat products, dealer services,
and industry solutions, visit us on the web at www.cat.com

© 2007 Caterpillar
All Rights Reserved
Printed in U.S.A.

Materials and specifications are subject to change without notice.
Featured machines in photos may include additional equipment.
See your Caterpillar dealer for available options.

AEHQ5656-01 (10-07)

Replaces AEHQ5656

CAT, CATERPILLAR, ACERT, SAFETY.CAT.COM, their respective logos, "Caterpillar Yellow"
and the POWER EDGE trade dress, as well as corporate and product identity used
herein, are trademarks of Caterpillar and may not be used without permission.

CATERPILLAR®